

The 4000E heating-unit is installed in the foundation slab or intermediate floor, and contains a fan and four heating elements, with contactors that are controlled by 1 - 4 external electric room thermostats. It is used together

with heating unit box 4000A 100/100 (100 mm / 4" spiral pipes) or with heating unit box 4000A 50/50 (50 mm / 2" plastic pipes).

TECHNICAL DATA

Operating voltage 1 P - 230V 60Hz
 Output, electrical..... 4 x 1000W
 Fan motor power consumption 165W
 Air flow w 8- 100 mm/4" pipe $\geq 900 \text{ m}^3/\text{h}$ (530 CFM)
 Air flow w 20 - 50 mm/2" pipe ... $\geq 750 \text{ m}^3/\text{h}$ (440 CFM)
 Breaker rating (GFI recommended)..... 30A

This data is generic. Each Legalett installation is unique. Refer to customized specifications on your installation design drawing for actual design parameters.

FUNCTION

The 4000E is controlled by one (single zone) to four (quad zone) external electric room thermostats. These external thermostats operate the contactors in the unit, energizing the heating coil and fan when the room needs heat. The unit is also equipped with seven overheating protection devices.

When controlled by a programmable thermostat, the 4000E can use two-tiered energy rates for night storage of less expensive energy in the LEGALETT heated floor.

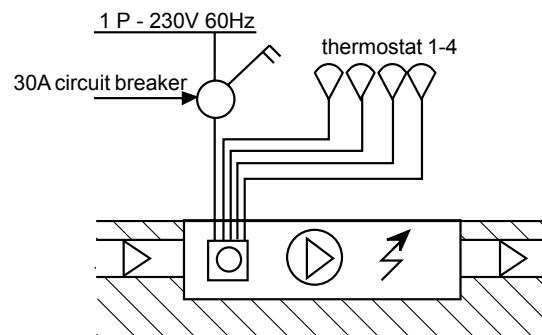

ASSEMBLY

Install the heating unit boxes in the correct location, with the height adjusted so that the lid is flush with the concrete surface, before pouring the concrete. Refer to the instructions on the box cover.

1. Run conduit from one of the cable inlets on the box to the local disconnect for 230V power. Run conduits from the remaining cable inlets to a convenient location above the slab for each of the 230V thermostats.
2. (Optional) For future conversion to water insert, run a conduit for an external 24V transformer (not supplied) and optional signal wiring to the boiler. As well, connect the sleeves for the inlet and outlet water pipes to the water pipe connections of the furnace box. Install the water pipes, and make sure they extend at least 100 mm (4") into the box.
3. After the concrete has dried sufficiently with the construction heater, prepare the box for the heating unit according to the steps below, which are performed by an authorized electrician and plumber.

4. Clean the furnace box carefully. No water or dampness should be in the box or pipe system when installing the permanent insert.
5. Install the heating unit insert with the terminal block turned towards the electric connection conduit openings.

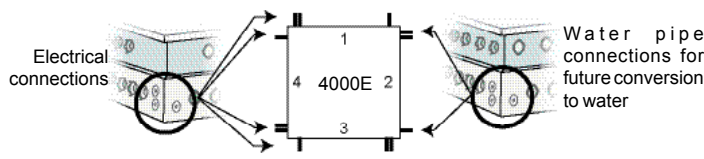
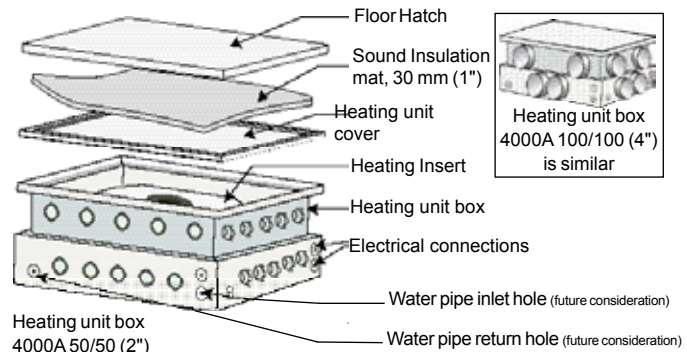

ELECTRICAL CONNECTIONS

1. Check the electrical data on the unit so that other installation materials are compatible. The installation must be performed by an authorized electrician.
2. Install a properly sized two-pole local disconnect to enable total isolation. GFI protection is recommended.
3. Use properly sized copper wire for connection to the panel.
4. Connect thermostats.
5. Seal the conduits which run into the unit using a duct sealing compound for both water and electrical, after the water and electrical connections have been made for sound attenuation.
6. Install the heating unit cover. Test run for 1 hour and then open for a check. If necessary clean, check for dryness, and test run again. If moisture is still present, re-install construction heater and run until the system is dry.
7. Install the sound insulating foam-rubber mat between the heating unit cover and the floor hatch.
8. Install the floor hatch. If desired, use standard transition trim between the hatch and the floor.

Overheating Protection

If the overheating protection has tripped, then complete the following steps:

1. Turn off the power.
2. Carefully investigate the reason for the overheating. Any repairs should only be performed by an authorized electrician.

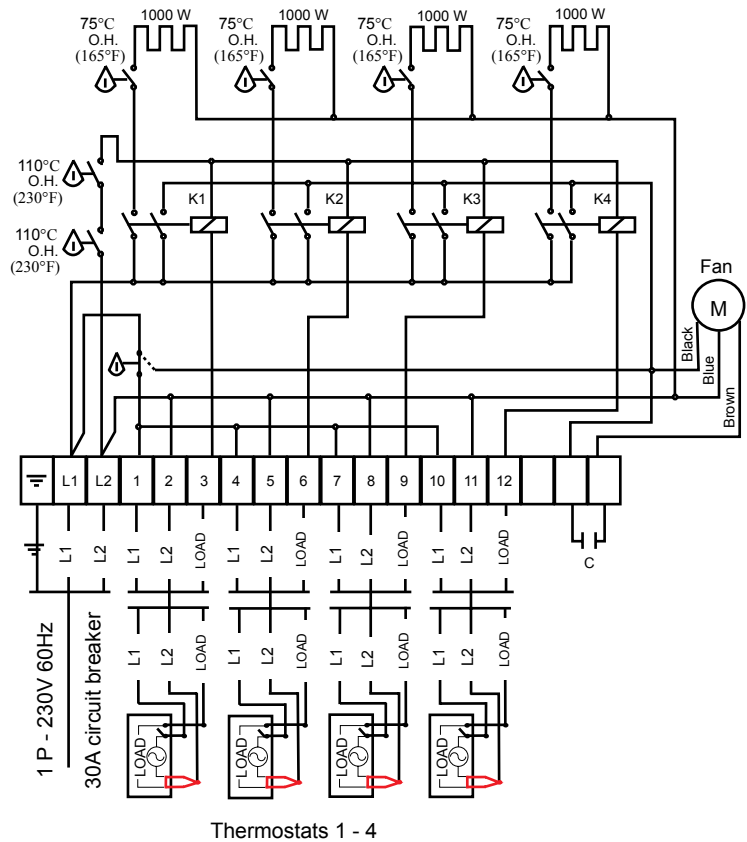

Contactors marked K1 - K4
O.H. = Overheating protection device

If 1 - 3 thermostats are used, install a jumper between the connection blocks 3 and 6, 9 and 12 as required.

Refer to the floor plan for thermostat locations.